

IMPORTANT! Please keep these instructions for future reference.
Please read these instructions before assembly and use of this product.

- Adult assembly is required.
- Product features and decorations may vary from illustrations.
- Do not use power drills or drivers.

Furniture Care Instructions

Room Climate Control

Wood, when first cut contains more than 50 percent water. When it is prepared for furniture construction it is placed in a Kiln and the moisture content is brought down to 8 to 10 percent. Wood is porous and responds to its environment. If the room has high humidity it will absorb it and expand and if the humidity is low it will lose moisture and shrink.

It is important that the humidity levels in the room be controlled from extremes of too much humidity or too little. Furniture should not be placed close to air-conditioning outlets, fireplaces, radiators, space heaters, humidifiers or dehumidifiers. Exposure to extreme variations of temperature and humidity can damage any fine wood product.

The Ideal Environment for Fine Furniture

Fine wood furniture will have fewer problems when its environment is controlled at a temperature between 65 and 75 degrees and a relative humidity between 35 and 40 percent. Wood placed in an environment outside of those limits can and will shrink or expand and may develop some small cracks which are not material or structural defects.

Sticking Doors and Drawers

With minor changes in temperature and humidity, doors and drawers may swell and be difficult to open or close. Tolerances have been built into the units but extreme conditions may still cause sticking. This will adjust back to normal over time but until it does, consider using a dehumidifier or rub candle wax or paraffin on the sides that stick.

Avoid Direct Sunlight

Keep the furniture out of direct sunlight. Ultraviolet rays will fade colors and in some cases darken them. It can also cause crazing or hair line cracks in the finish. White finishes will yellow naturally over time and exposure to direct sunlight will hasten this natural process along with some woods darkening naturally over time; this is not considered to be a quality defect.

Proper Storage

If you need to put your furniture in storage for any period of time, do not place furniture in a damp basement or hot dry attic. Allow air movement around the furniture and do not stack anything on it.

In General

- Protect furniture surface from hot or extremely cold items.
- Use coasters under hot or cold beverages.
- Do not use synthetic fabric under accessories or lamps.
- Protect tops from pens, markers and crayons.
- Oils from potpourri and other scented items can damage the furniture finish.
- Do not drag items across the surface of the furniture.
- Allow the surface to breath by rotating your accessories and lamps.
- Do not over polish the furniture, do it only two or three times a year. Over polishing can distort the natural finish of the product.
- Do not wax the furniture as wax build up can destroy the natural finish of the product.
- When moving furniture always lift the unit. Do not push or drag it to avoid damage to the legs.
- Keep the furniture level so doors and drawers open and close freely.
- Clean with a damp, not wet, cloth. Use only a mild soap. Do not use abrasive cleaners.

STOP

**IF YOU EXPERIENCE ANY
ISSUES WITH THIS PRODUCT**

**BEFORE YOU
RETURN THIS TO
THE RETAILER**

**PLEASE FOLLOW
PROCEDURES ON THE
BACK PAGE**

PART LIST

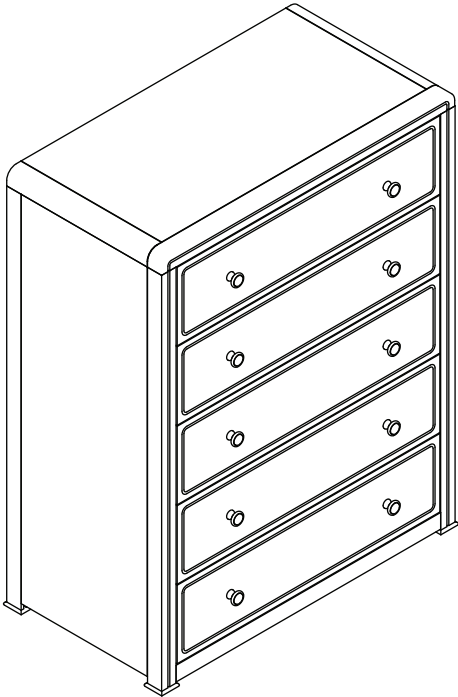

A. 5 drawer chest x1

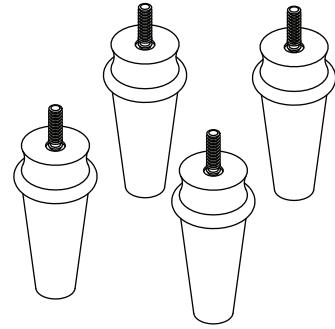

B. Feet x4

C. Anti-Tip Kit x 1bag
(Instruction and Hardware inside)

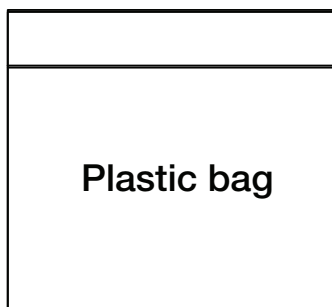

Plastic bag

ASSEMBLY INSTRUCTIONS

Note: 2 Adults Needed for Assembly

Please assemble feet (A) to 5 Drawer Chest bottom as shown in figure.

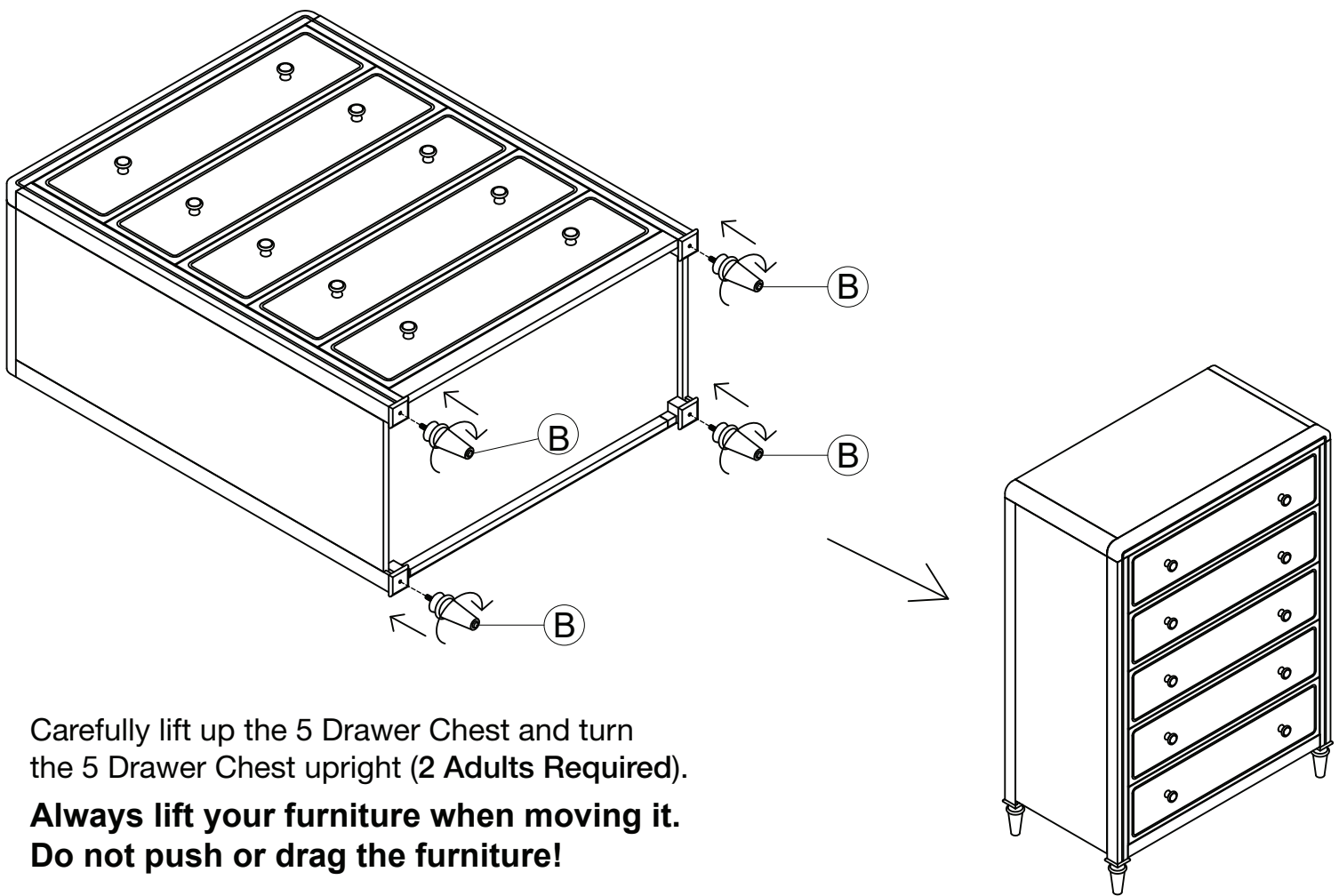

Note: Please follow instructions in Anti-Tip Kit located on back of Case when assembly is complete.

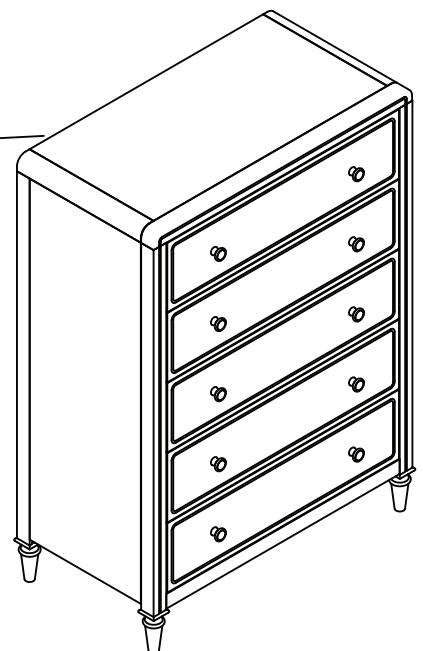

Note: Product features and decorations may vary from illustration.

Product Assistance Procedures

You have purchased a quality piece of furniture. Our International team has spent many hours designing and engineering this piece and packaging to ensure you will be satisfied with your purchase. But if for any reason you need help with your purchase please contact us at any time.

Procedures to follow should you have any questions:

Most inquiries can be answered by visiting our website. There, you can order parts, find assembly instructions, and get answers to frequently asked questions on all of our brands.

You can also email us. In order for us to provide you with the best service possible, please include the following information in your email:

1. Your Name
2. Address
3. Phone Number
4. Item Number and description of your product
5. PO#
6. Production Date

All product information will be on the product label located on the back of all dressers and other furniture, and on either the inside bottom of the headboard, crib ends, or stabilizer bar of your crib, depending on which model you have.

Someone will contact you via e-mail or phone to help you with your issues.

If you do not have internet access, you can fax your information to us.

If you do not have internet or fax access, please call us at our toll free number. Be sure to have all of the above information ready to give to your Customer Service Specialist.

Contact

U.S.A & CANADA

Bivona & Company®, LLC
701 Boutwell Rd, Suite A-3, Lake Worth Florida.
Toll Free: 1-888-963-8125
Fax: 732-527-0664
Zip code : 33461
Website: www.bivonaco.com
Email: info@bivonaco.com

Manufactured for and distributed in the United States & Canada by: Bivona & Company®, LLC
LLC 701 Boutwell Rd, Suite A-3, Lake Worth Florida.

MADE IN VIETNAM